

4

3

2

1

REVISIONS					
ZONE	REV.	DESCRIPTION	DRAWN	DATE	APPROVED

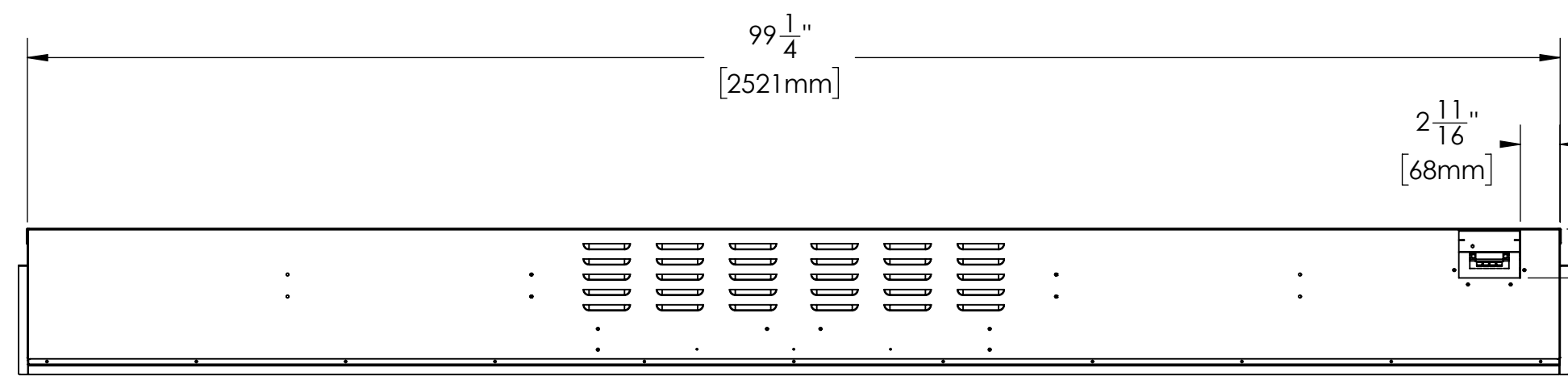
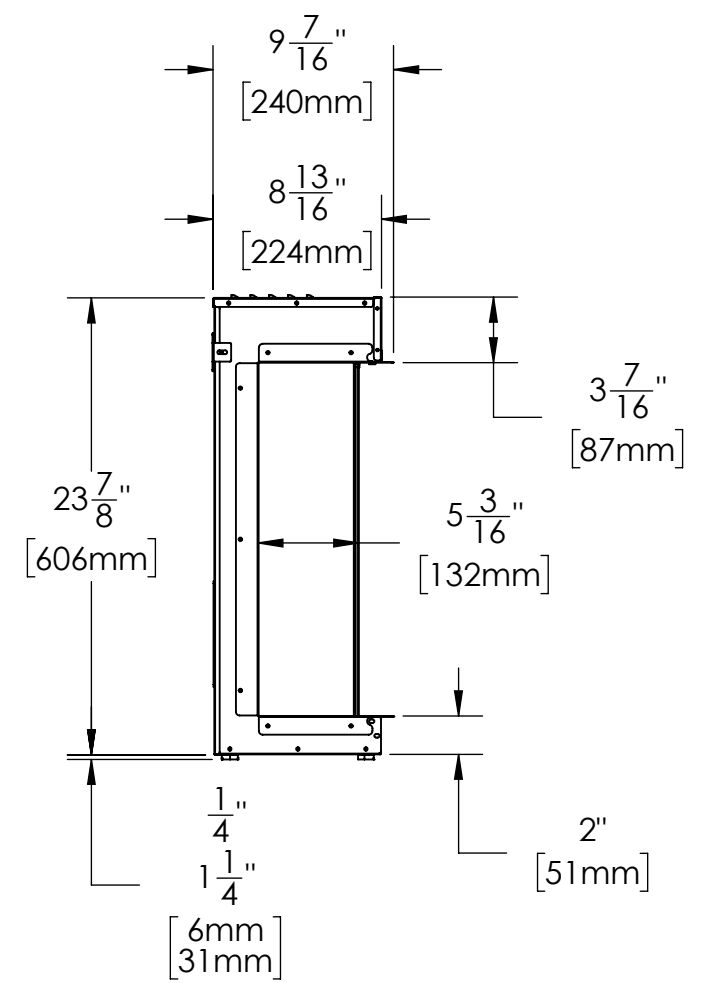
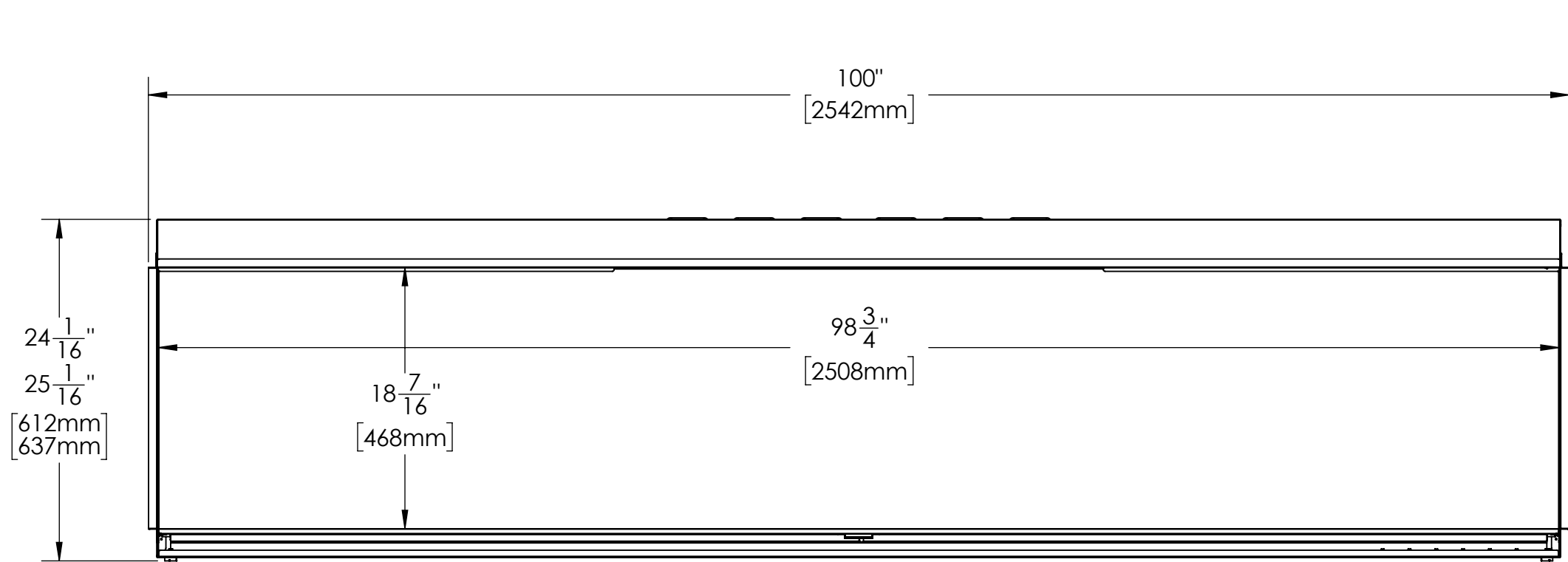

UNLESS OTHERWISE SPECIFIED:
 DIMENSIONS ARE IN INCHES
 TOLERANCES:
 FRACTIONAL ±1/16"
 ANGULAR: MACH ±2° BEND ±2°
 ONE PLACE DECIMAL ±.1
 TWO PLACE DECIMAL ±.06
 THREE PLACE DECIMAL ±.030

INTERPRET GEOMETRIC TOLERANCING PER:
 MATERIAL
 FINISH
 DO NOT SCALE DRAWING

	NAME	DATE
DRAWN		
CHECKED		
ENG APPR.		
MFG APPR.		
Q.A.		

PROPRIETARY AND CONFIDENTIAL
 THE INFORMATION CONTAINED IN THIS DRAWING IS THE SOLE PROPERTY OF RICHARDSON PRODUCTS GROUP (RPG BRANDS). ANY REPRODUCTION IN PART OR AS A WHOLE WITHOUT THE WRITTEN PERMISSION OF RICHARDSON PRODUCTS GROUP (RPG BRANDS) IS PROHIBITED.

RPG BRANDS

TITLE: ORION MULTI 100" V1 & V2

SIZE	DWG. NO.	REV
B	OR100-Multi	

SCALE: 1:10 WEIGHT: SHEET 1 OF 1

4

3

2

1